

Chandler, AZ (800) 380-0103 (480) 838-5329

DESIGN-A-SHIELD - MODULAR TRENCH SHIELD SYSTEMS

TABULATED DATA

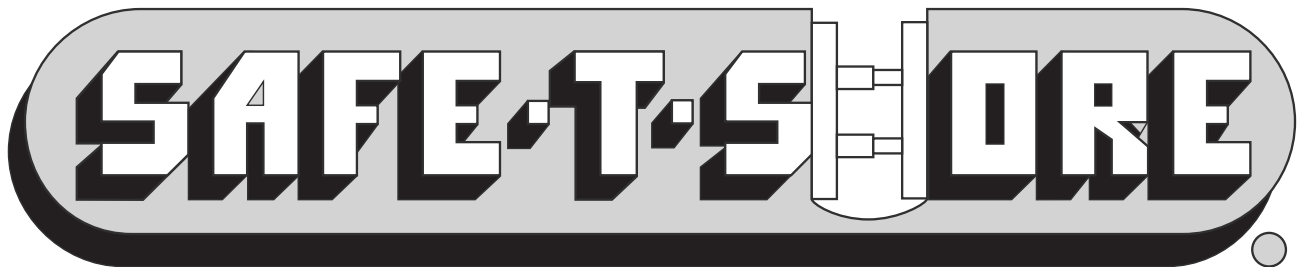

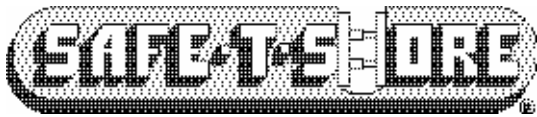

Tempe, AZ (800) 380-0103 (480) 838-5329
DESIGN-A-SHIELD MODULAR TRENCH SHIELD SYSTEMS
TABULATED DATA

1. SITE LIMITATIONS:

a. DESIGN-A-SHIELD MODULAR TRENCH SHIELD SYSTEMS TABULATED DATA has been prepared in accordance with OSHA Rules and Regulations as defined in 29 CFR, Part 1926, Subpart P –“Excavations and Trenches.”

b. This data is to be used by a soils engineer, or a competent person. Competent person, as defined in Part 1926, means one who is capable of identifying existing and predictable hazards in the surroundings, or working conditions which are unsanitary, hazardous, or dangerous to employees, and who has authorization to take prompt corrective measures to eliminate them. The competent person shall be experienced in and knowledgeable of excavation and trenching procedures, the use of modular trench shield systems, soils identification and the OSHA Rules and Regulations.

c. The competent person shall continually monitor the excavation for signs of deterioration such as seepage of water or flowing soil into the excavation. Changing soil conditions may require adjustments to the modular trench shield systems.

d. The tabulated data shall be used only for those soil conditions indicated. The depth ratings in the data are not considered adequate when additional loads imposed by structures, equipment, and stored materials adjacent to the trench are present. More severe conditions require the services of a soils engineer to determine the lateral soil pressure.

e. The tabulated data PSF Ratings and Depth Certification are based on short term and long-term exposures. Short term is defined as a period of time equal to or less than 24 hours and long term is defined as a period of time greater than 24 hours. Proper backfill sufficient to stabilize the DESIGN-A-SHIELD and to minimize ground surface and/or foundation settlements is required. Where such settlements are not a concern, over digging may be performed, however, the clear distance shall not exceed 6” (see Pg. 5) and the more restrictive long term tabulated depth ratings shall be used.

f. No vertical or horizontal loads shall be applied to the adjustable strut or static braces except as specified by Safe-T-Shore. Any mishandling, such as pounding with the backhoe bucket, will void the tabulated data.

2. SOIL CLASSIFICATION:

Types "A", "B" and “C-60” soil classifications are as delineated below and they are based on Appendix A to 29 CFR, Part 1926, Subpart P.

a. Type "A" Soil -Equivalent weight effect of 25 psf per foot of depth. Description: Cohesive soils (i.e. silty clay loam and sandy clay loam) with an unconfined compressive strength of 1.5 tsf or greater, or cemented soils such as caliche and hardpan. No soil is Type "A" if the soil is fissured; subject to vibration from heavy traffic, pile driving or similar effects; has been previously disturbed; or part of a sloped, layered system where the layers dip into the excavation on a slope of four horizontal to one vertical (4H:1V) or greater.

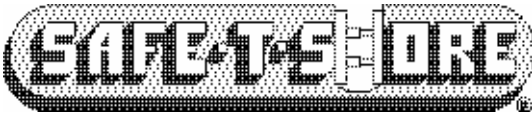

Chandler, AZ (800) 380-0103 (480) 838-5329
DESIGN-A-SHIELD MODULAR TRENCH SHIELD SYSTEMS
TABULATED DATA

2b. Type " B " Soil -Equivalent weight effect of 45 psf per foot of depth.

Description: Cohesive soil with an unconfined compressive strength greater than .5 tsf but less than 1.5 tsf; or granular cohesionless soils including angular gravel (similar to crushed rock), silt, silt loam, sandy loam, and, in some cases, silty clay loam and sandy clay loam; previously disturbed soils except those which would otherwise be classed as Type "C-60"; soil that meets requirements for Type "A", but is fissured or subject to vibration: dry rock that is unstable; or material that is part of a layered system where layers dip into the excavation on a slope less steep than four horizontal to one vertical (4H:1V), but only if the material would otherwise be classified as Type "B".

2c. Type "C-60" Soil -Equivalent weight effect of 60 psf per foot of depth.

Description: Cohesive soil with an unconfined compressive strength of .5 tsf or less; moist cohesive soil or moist dense sand which is not flowing or submerged; when cut with near vertical sidewalls, soil can stand with unsupported sidewalls long enough for shield installation; granular soils including gravel, sand and loam sand; soil in a sloped system where the layers dip into the excavation on a slope of four horizontal to one vertical (4H:1 V) or steeper may be Type "C-60". Submerged soil is material with water freely seeping and entering the trench, but only part of the depth of the retained soil is submerged. Conditions more severe would require dewatering or sealing four sides of the excavation and pumping the trench. Such severe conditions would require the services of a soils engineer to establish the design pressure. Consult Safe-T-Shore for pressures exceeding tabulated values.

3. DATA LIMITATIONS:

- a.** When the shield is to be used in a sloped excavation with an angle steeper than three horizontal to one vertical (3H:1V), the allowable depth of excavation shall be measured from the top of the overall trench and not the toe of the sloped portion.
- b.** In sloped excavations, the top of the shield must be a minimum of 18 inches above the bottom of the slope and the top struts/braces must be located below the bottom of the slope. In un-sloped excavations, the top of the shield may be flush with the ground surface, provided that the competent person determines that there is no hazard of objects rolling into the excavation.
- c.** DESIGN-A-SHIELD Modular Trench Shield Systems shall be used with Safe-T-Shore adjustable struts and static braces pinned in place with two (2) Safe-T-Shore supplied 5/8" diameter pins at each end of the strut or brace as illustrated on page 5.
- d.** DESIGN-A-SHIELD Modular Trench Shield Systems shall be assembled and installed as shown and in accordance with these instructions. Note that installation videos and training at Safe-T-Shore are available upon request.
- e.** DESIGN-A-SHIELD Modular Trench Shield Systems shall be handled by using the lifting lugs installed in holes provided in each panel or corner post. Stacking Brackets shall be used when stacking modular systems.
- f.** The bottom of the DESIGN-A-SHIELD shall be located no more than two feet from the bottom of the excavation in soil Types "A", "B" and "C-60" as long as no loss of soil from behind or below the shield is encountered. Proper benching of trench wall is required.

SAFE-T-SHORE, CHANDLER, AZ (800) 380-0103 (480) 838-5329
DESIGN-A-SHIELD MODULAR TRENCH SHIELD SYSTEMS
SELECTION GUIDE
FULL LENGTH CORNER POSTS

PANEL SELECTION CHART		DEPTH CHART FOR 2-SIDED BOX			
Model (Ht. x Lg. in Ft.)	Weight (in Lbs.)	Shield Capacity (PSF)	Depth of Cut (Ft.) Soil		
			A	B	C-60
23 BBP	40	2,400	96	53	40
24 BBP	52	1,920	77	43	32
26 BBP	76	1,320	53	29	22
28 BBP	100	1,020	41	23	17
210 BBP	124	840	34	19	14
212 BBP	148	660	26	15	11
214 BBP	170	540	22	12	9
216 BBP	194	480	19	11	8

DEPTH CHART FOR 3 - OR 4 - SIDED BOX				
Width x Length (in Ft.)	PSF ratings	Depth of Cut (Ft.) Soil Type		
		A	B	C-60
4 X 8	1,020	41	23	17
4 X 10	780	31	17	13
4 X 12	600	24	13	10
4 X 14	540	22	12	9
4 X 16	480	19	11	8
6 X 6	1,320	53	29	22
6 X 8	1,020	41	23	17
6 X 10	720	29	16	12
6 X 12	600	24	13	10
6 X 14	540	22	12	9
6 X 16	480	19	11	8
8 X 8	1,020	41	23	17
8 X 10	720	29	16	12
8 X 12	540	22	12	9
8 X 14	480	19	11	8
8 X 16	480	19	11	8
10 X 10	660	26	15	11
10 X 12	540	22	12	9
10 X 14	480	19	11	8
10 X 16	480	19	11	8
12 X 12	540	22	12	9
12 X 14	480	19	11	8
12 X 16	480	19	11	8
14 X 14	480	19	11	8
14 X 16	480	19	11	8
16 X 16	480	19	11	8

NOTES:

- (1) NUMEROUS OTHER COMBINATIONS OF PANELS, CORNER POSTS, T-POSTS, 4-WAY POSTS AND STRUTS, OTHER THAN THOSE SHOWN ON PAGE 5, ARE PERMISSABLE WITH APPROVAL FROM SAFE-T-SHORE.
- (2) DESIGN-A-SHIELD MODULAR TRENCH SHIELD SYSTEMS, ARE DESIGNED FOR USE WITH SAFE-T-SHORE ADJUSTABLE STRUTS AND STATIC BRACES.



SAFE-T-SHORE, CHANDLER, AZ (800) 380-0103 (480) 838-5329
DESIGN-A-SHIELD MODULAR TRENCH SHIELD SYSTEMS
SELECTION GUIDE (Additional Configurations)
FULL LENGTH CORNER POSTS

PANEL SELECTION CHART		DEPTH CHART FOR 2-SIDED BOX			
Model (Ht. x Lg. in Ft.)	Weight (in Lbs.)	Shield Capacity (PSF)	Depth of Cut (Ft.) Soil		
			A	B	C-60
22 BBP	28	2,400	96	53	40
23 BBP	40	2,400	96	53	40
24 BBP	52	2,400	96	53	40
25 BBP	64	2,400	96	53	40
26 BBP	76	2,400	96	53	40
27 BBP	88	1,740	70	39	29
28 BBP	100	1,440	58	32	24
210 BBP	124	960	38	21	16
212 BBP	148	780	31	17	13
214 BBP	170	600	24	13	10
216 BBP	194	480	19	11	8

DEPTH CHART FOR 3 OR 4 SIDED BOX				
Width x Length (in Ft.)	PSF ratings	Depth of Cut (Ft.) Soil Type		
		A	B	C-60
4 X 4	1,620	65	36	27
4 X 5	1,500	60	33	25
4 X 6	1,320	53	29	22
4 X 7	1,140	46	25	19
5 X 5	1,500	60	33	25
5 X 7	1,140	46	25	19
6 X 5	1,320	53	29	22
6 X 7	1,140	46	25	19
7 X 7	1,140	46	25	19
8 X 5	1,020	41	23	17
8 X 7	1,020	41	23	17
10 X 5	780	31	17	13
10 X 7	720	29	16	12
12 X 5	600	24	13	10
12 X 7	600	24	13	10
14 X 5	540	22	12	9
14 X 7	540	22	12	9
16 X 5	480	19	11	8
16 X 7	480	19	11	8

NOTES:

- (1) NUMEROUS OTHER COMBINATIONS OF PANELS, CORNER POSTS, T-POSTS, 4-WAY POSTS AND STRUTS, OTHER THAN THOSE SHOWN ON PAGE 5, ARE PERMISSABLE WITH APPROVAL FROM SAFE-T-SHORE.
- (2) DESIGN-A-SHIELD MODULAR TRENCH SHIELD SYSTEMS, ARE DESIGNED FOR USE WITH SAFE-T-SHORE ADJUSTABLE STRUTS AND STATIC BRACES.

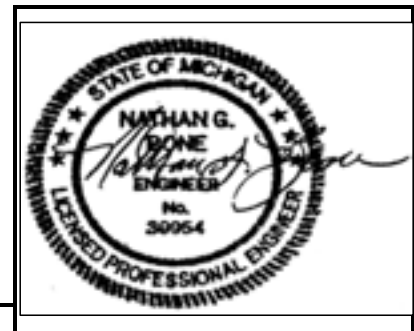

SAFE-T-SHORE, CHANDLER, AZ (800) 380-0103 (480) 838-5329
DESIGN-A-SHIELD MODULAR TRENCH SHIELD SYSTEMS
SELECTION GUIDE
SECTIONAL CORNER POSTS

PANEL SELECTION CHART		DEPTH CHART FOR 2-SIDED BOX			
Model (Ht. x Lg. in Ft.)	Weight (in Lbs.)	Shield Capacity (PSF)	Depth of Cut (Ft.) Soil		
			A	B	C-60
23 BBP	40	2,400	96	53	40
24 BBP	52	2,400	96	53	40
26 BBP	76	2,400	96	53	40
28 BBP	100	1,440	58	32	24
210 BBP	124	960	38	21	16
212 BBP	148	780	31	17	13
214 BBP	170	600	24	13	10
216 BBP	194	480	19	11	8

DEPTH CHART FOR 3 OR 4 SIDED BOX				
Width x Length (in Ft.)	PSF ratings	Depth of Cut (Ft.) Soil Type		
		A	B	C-60
4 X 8	1,320	53	29	22
4 X 10	900	36	20	15
4 X 12	780	31	17	13
4 X 14	600	24	13	10
4 X 16	480	19	11	8
6 X 6	2,040	82	45	34
6 X 8	1,260	50	28	21
6 X 10	840	34	19	14
6 X 12	780	31	17	13
6 X 14	600	24	13	10
6 X 16	480	19	11	8
8 X 8	1,200	48	27	20
8 X 10	840	34	19	14
8 X 12	720	29	16	12
8 X 14	540	22	12	9
8 X 16	480	19	11	8
10 X 10	780	31	17	13
10 X 12	720	29	16	12
10 X 14	540	22	12	9
10 X 16	480	19	11	8
12 X 12	660	26	15	11
12 X 14	540	22	12	9
12 X 16	480	19	11	8
14 X 14	480	19	11	8
14 X 16	480	19	11	8
16 X 16	480	19	11	8

NOTES:

- (1) NUMEROUS OTHER COMBINATIONS OF PANELS, CORNER POSTS, T-POSTS, 4-WAY POSTS AND STRUTS, OTHER THAN THOSE SHOWN ON PAGE 5, ARE PERMISSABLE WITH APPROVAL FROM SAFE-T-SHORE.
- (2) DESIGN-A-SHIELD MODULAR TRENCH SHIELD SYSTEMS, ARE DESIGNED FOR USE WITH SAFE-T-SHORE ADJUSTABLE STRUTS AND STATIC BRACES.

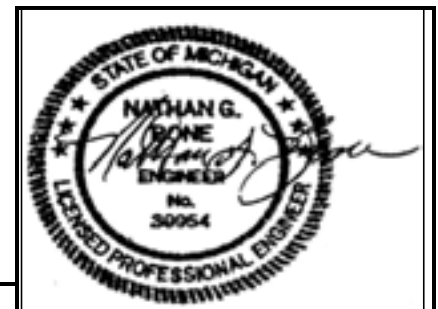

SAFE-T-SHORE, CHANDLER, AZ (800) 380-0103 (480) 838-5329
DESIGN-A-SHIELD MODULAR TRENCH SHIELD SYSTEMS
SELECTION GUIDE (Additional Configurations)
SECTIONAL CORNER POSTS

PANEL SELECTION CHART		DEPTH CHART FOR 2-SIDED BOX			
Model (Ht. x Lg. in Ft.)	Weight (in Lbs.)	Shield Capacity (PSF)	Depth of Cut (Ft.) Soil		
			A	B	C-60
22 BBP	28	2,400	96	53	40
23 BBP	40	2,400	96	53	40
24 BBP	52	2,400	96	53	40
25 BBP	64	2,400	96	53	40
26 BBP	76	2,400	96	53	40
27 BBP	88	1,740	70	39	29
28 BBP	100	1,440	58	32	24
210 BBP	124	960	38	21	16
212 BBP	148	780	31	17	13
214 BBP	170	600	24	13	10
216 BBP	194	480	19	11	8

DEPTH CHART FOR 3 OR 4 SIDED BOX				
Width x Length (in Ft.)	PSF ratings	Depth of Cut (Ft.) Soil Type		
		A	B	C-60
4 X 4	2,160	86	48	36
4 X 5	2,100	84	47	35
4 X 6	2,040	82	45	34
4 X 7	1,620	65	36	27
5 X 5	2,100	84	47	35
5 X 7	1,620	65	36	27
6 X 5	2,040	82	45	34
6 X 7	1,620	65	36	27
7 X 7	1,620	65	36	27
8 X 5	1,200	48	27	20
8 X 7	1,200	48	27	20
10 X 5	900	36	20	15
10 X 7	840	34	19	14
12 X 5	780	31	17	13
12 X 7	720	29	16	12
14 X 5	600	24	13	10
14 X 7	540	22	12	9
16 X 5	480	19	11	8
16 X 7	480	19	11	8

NOTES:

- (1) NUMEROUS OTHER COMBINATIONS OF PANELS, CORNER POSTS, T-POSTS, 4-WAY POSTS AND STRUTS, OTHER THAN THOSE SHOWN ON PAGE 5, ARE PERMISSABLE WITH APPROVAL FROM SAFE-T-SHORE.
- (2) DESIGN-A-SHIELD MODULAR TRENCH SHIELD SYSTEMS, ARE DESIGNED FOR USE WITH SAFE-T-SHORE ADJUSTABLE STRUTS AND STATIC BRACES.



Design-A-Shield

Examples of Typical Installations

Sectional Corner Posts

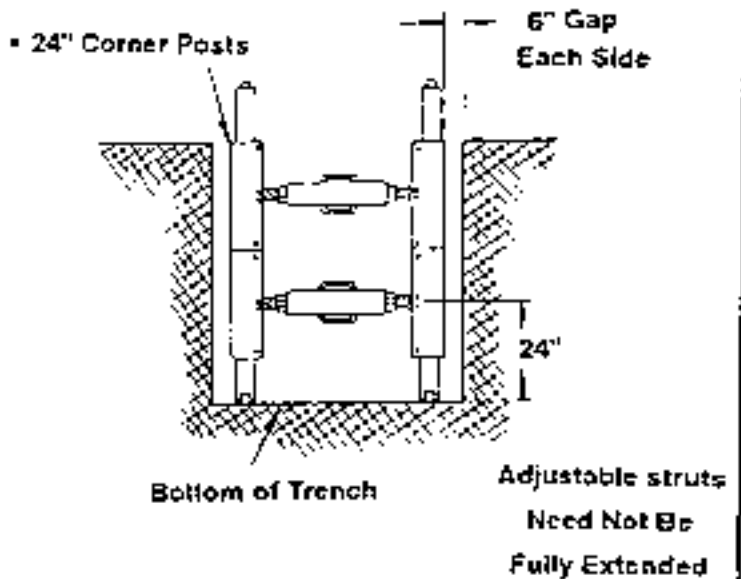
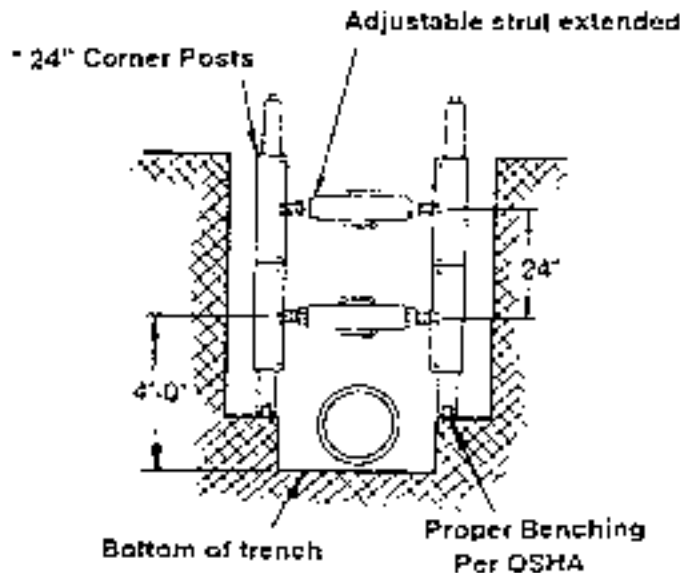

Full Length Corner Post

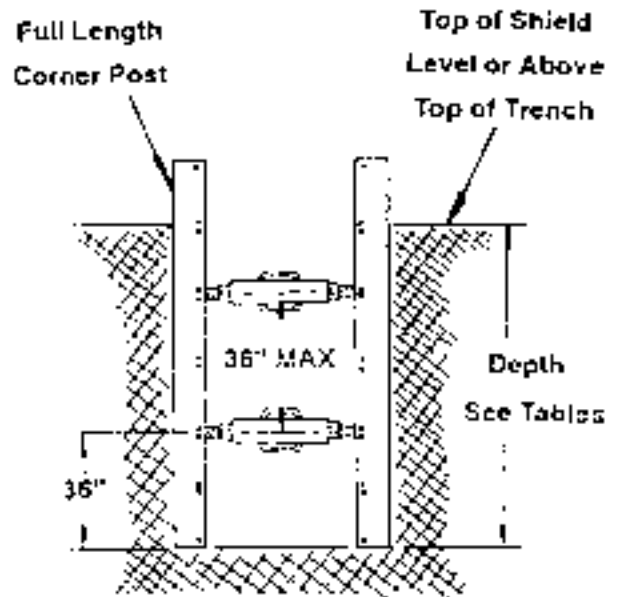
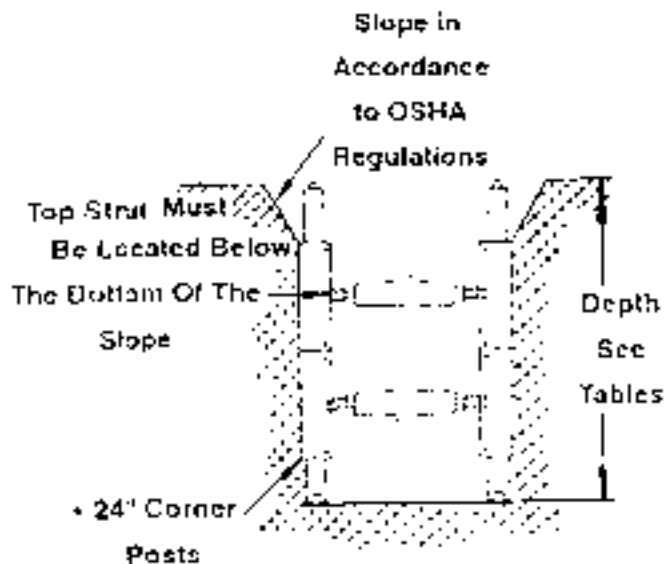

NOTE: Alternate installation and trenching methods shown on sectional corner posts also apply

* WHEN Sectional corner posts are used an Adjustable strut is required at each panel joint. Specifications are available from manufacturer.

SAFE-T-SHORE, CHANDLER, AZ (800) 380-0103
DESIGN-A-SHIELD MODULAR TRENCH SHIELD SYSTEMS - Addendum A
SELECTION GUIDE

6' OR 7' FULL LENGTH CORNER POSTS: BAS-57: 5'-7' MAX. ADJ. STRUTS
48" (c.c.) LOWER STRUT CLEARANCE - SEE NOTE 2 FOR STRUT C.C. SPACING

PANEL SELECTION CHART		DEPTH CHART FOR 2-SIDED BOX			
Model (Ht. x Lg. in Ft.)	Weight (in Lbs.)	Shield Capacity (PSF)	Depth of Cut (Ft.) Soil		
			A	B	C-80
22 BBP	28	1,860	74	41	31
23 BBP	40	1,260	50	28	21
24 BBP	52	960	38	21	16
25 BBP	64	780	31	17	13
26 BBP	76	600	25	14	10
27 BBP	88	600	23	13	10
28 BBP	100	480	20	11	8
29 BBP	112	480	18	10	8
210 BBP	124	420	16	9	7
212 BBP	148	360	14	8	6
214 BBP	170	300	13	7	5
216 BBP	194	240	11	6	4

DEPTH CHART FOR 3 SIDED BOX USING 6' OR 7' POSTS				
Width x Length (in Ft.)	PSF ratings	Depth of Cut (Ft.) Soil Type		
		A	B	C-60
up to 7 X 2	1,860	74	41	31
up to 7 X 3	1,260	50	28	21
up to 7 X 4	960	38	21	16
up to 7 X 5	780	31	17	13
up to 7 X 6	600	25	14	10
up to 7 X 7	600	23	13	10
up to 7 X 8	480	20	11	8
up to 7 X 9	480	18	10	8
up to 7 X 10	420	16	9	7
up to 7 X 12	360	14	8	6
up to 7 X 14	300	13	7	5
up to 7 X 16	240	11	6	4

NOTES:

- (1) COMBINATIONS OF PANELS, CORNER POSTS, T-POSTS, 4-WAY POSTS AND STRUTS, OTHER THAN THOSE SHOWN ON PAGE 5. ARE PERMISSABLE WITH APPROVAL FROM EFFICIENCY.
- (2) BUILD-A-BOX MODULAR TRENCH SHIELD SYSTEMS. ARE DESIGNED FOR USE WITH EFFICIENCY ADJUSTABLE STRUTS AND STATIC BRACES
 STRUT C.C. SPACING FOR 6' POST = 1' ONLY,
 STRUT C.C. SPACING FOR 7' POST = 2' ONLY.



SAFE-T-SHORE, CHANDLER, AZ (800) 380-0103
DESIGN-A-SHIELD MODULAR TRENCH SHIELD SYSTEMS - Addendum A
SELECTION GUIDE

8', 9' OR 10' FULL LENGTH CORNER POSTS: BAS-79:
7'-9' MAX. ADJ. STRUTS 48" (c.c.) LOWER STRUT CLEARANCE

***** SEE NOTE 2 FOR STRUT C.C. SPACING *****

PANEL SELECTION CHART		DEPTH CHART FOR 2-SIDED BOX			
Model (Ht. x Lg. in Ft.)	Weight (in Lbs.)	Shield Capacity (PSF)	Depth of Cut (Ft.) Soil		
			A	B	C-60
22 BBP	28	2,400	95	53	40
23 BBP	40	1,680	67	37	28
24 BBP	52	1,260	50	28	21
25 BBP	64	1,020	41	23	17
26 BBP	76	840	34	19	14
27 BBP	88	660	31	17	11
28 BBP	100	660	27	15	11
29 BBP	112	600	23	13	10
210 BBP	124	540	22	12	9
212 BBP	148	480	18	10	8
214 BBP	170	420	16	9	7
216 BBP	194	360	14	8	6

DEPTH CHART FOR 3 SIDED BOX USING 8', 9' or 10' POSTS				
Width x Length (in Ft.)	PSF ratings	Depth of Cut (Ft.) Soil Type		
		A	B	C-60
up to 9 X 2	2,400	95	53	40
up to 9 X 3	1,680	67	37	28
up to 9 X 4	1,260	50	28	21
up to 9 X 5	1,020	41	23	17
up to 9 X 6	840	34	19	14
up to 9 X 7	660	31	17	11
up to 9 X 8	660	27	15	11
up to 9 X 9	600	23	13	10
up to 9 X 10	540	22	12	9
up to 9 X 12	480	18	10	8
up to 9 X 14	420	16	9	7
up to 9 X 16	360	14	8	6

NOTES:

- 11) NUMEROUS OTHER COMBINATIONS OF PANELS, CORNER POSTS, T-POSTS, 4-WAY POSTS AND STRUTS, OTHER THAN THOSE SHOWN ON PAGE 5, ARE PERMISSABLE WITH APPROVAL FROM EFFICIENCY
- 12) BUILD-A-BOX MODULAR TRENCH SHIELD SYSTEMS, ARE DESIGNED FOR USE WITH EFFICIENCY ADJUSTABLE STRUTS AND STATIC BRACES
 STRUT C C SPACING FOR 8' POSTS = 3' ONLY.
 STRUT C C SPACING FOR 9' POSTS = 3' ONLY.
 STRUT C C SPACING FOR 10' POSTS = 3' OR 4'

